

**B1 MECH UNIT STEEL BASE FRAME**  
S-514 SCALE: 1" = 1'-0"

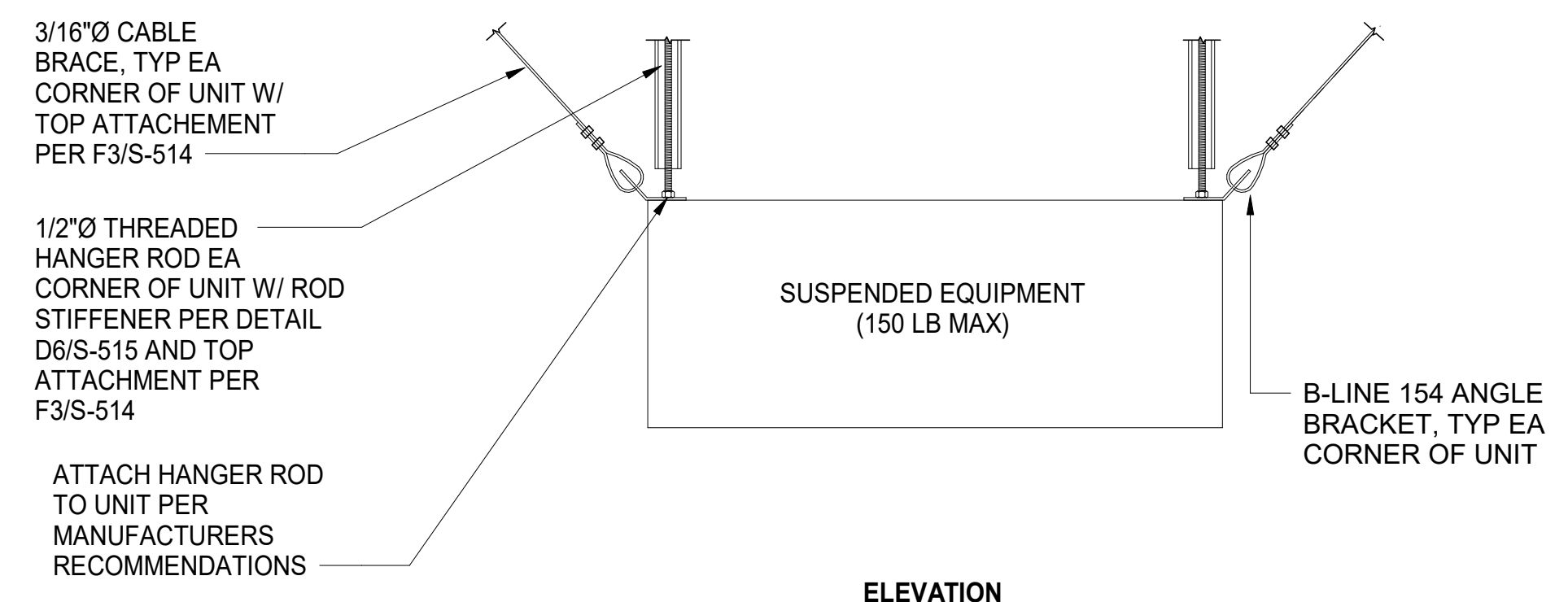

**B4 TYPICAL SUSPENDED EQUIPMENT BRACING DETAIL**  
S-514 SCALE: 1" = 1'-0"

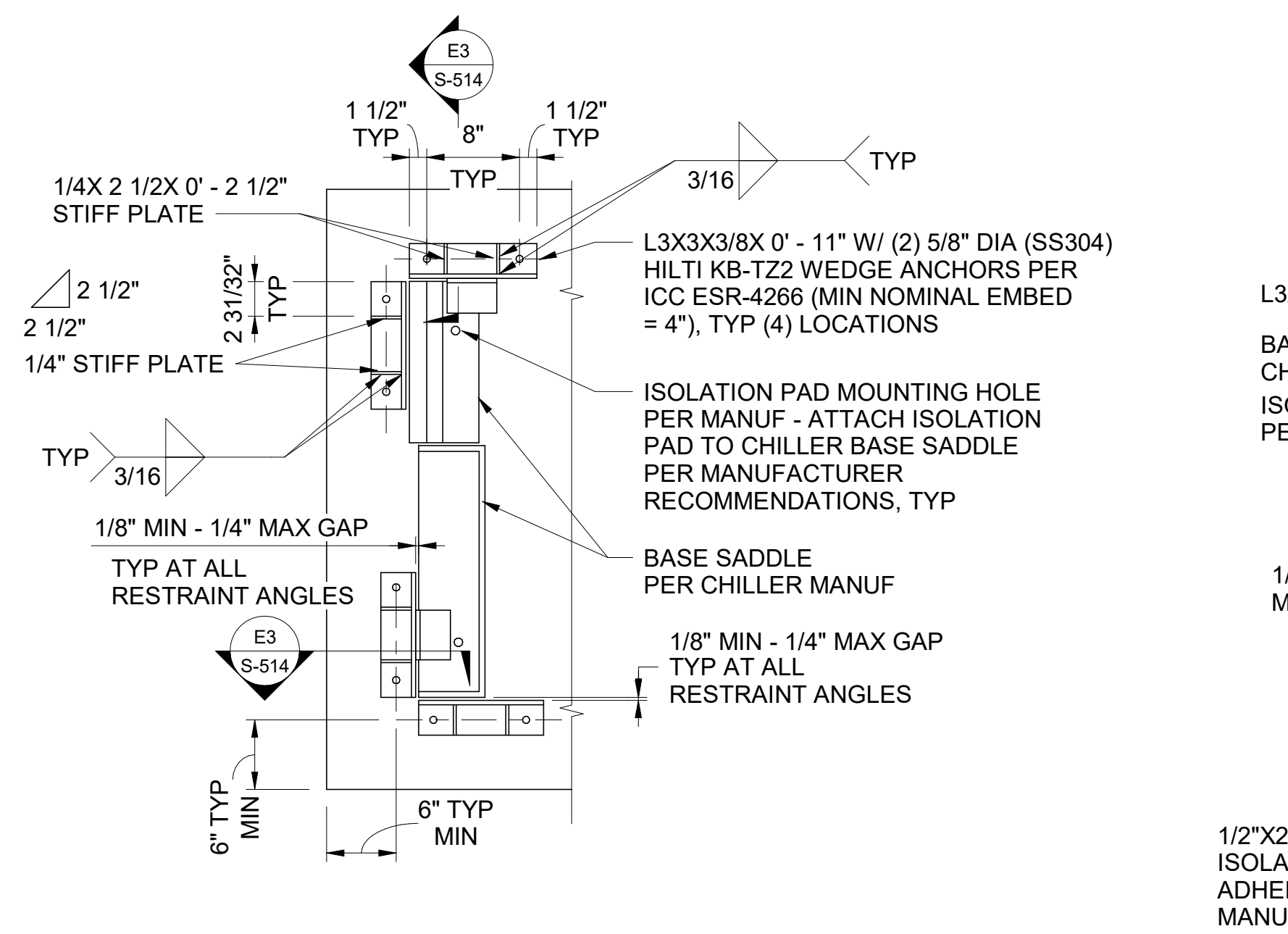
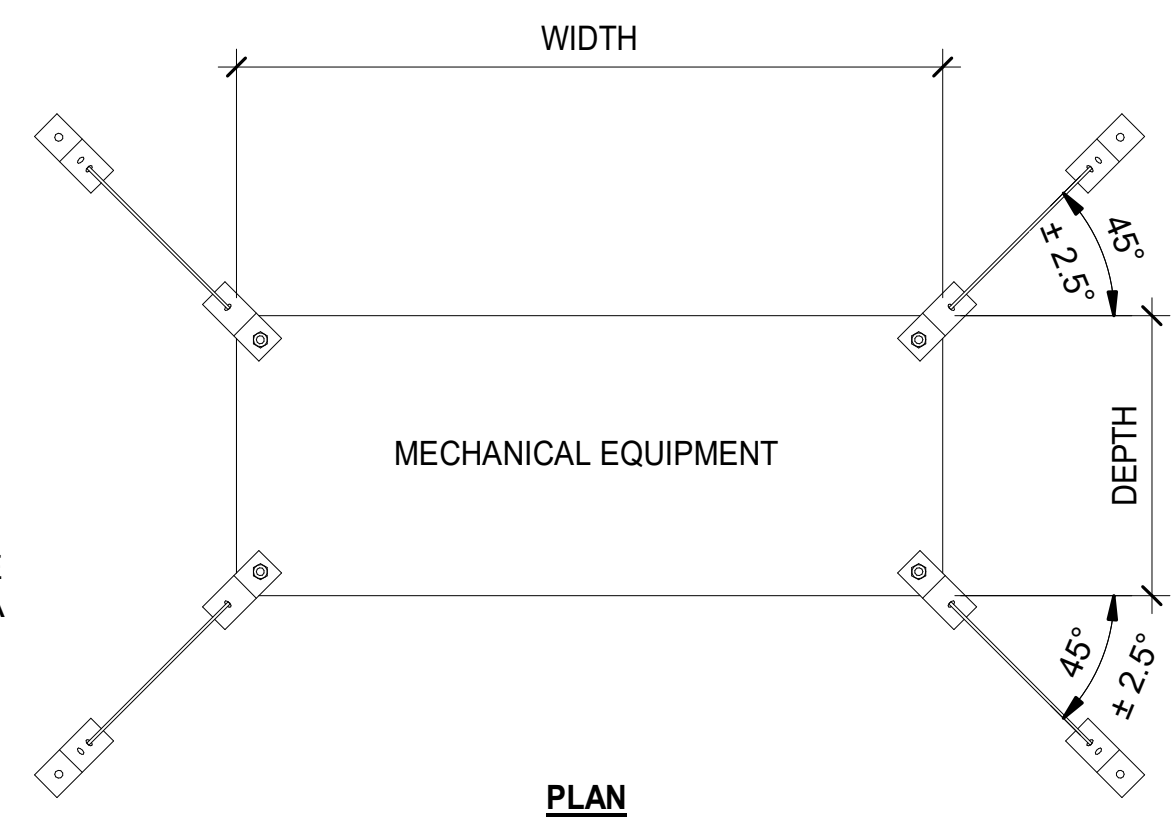

**E1 CHILLER UNIT ANCHORAGE DETAIL**  
S-514 SCALE: 1" = 1'-0"

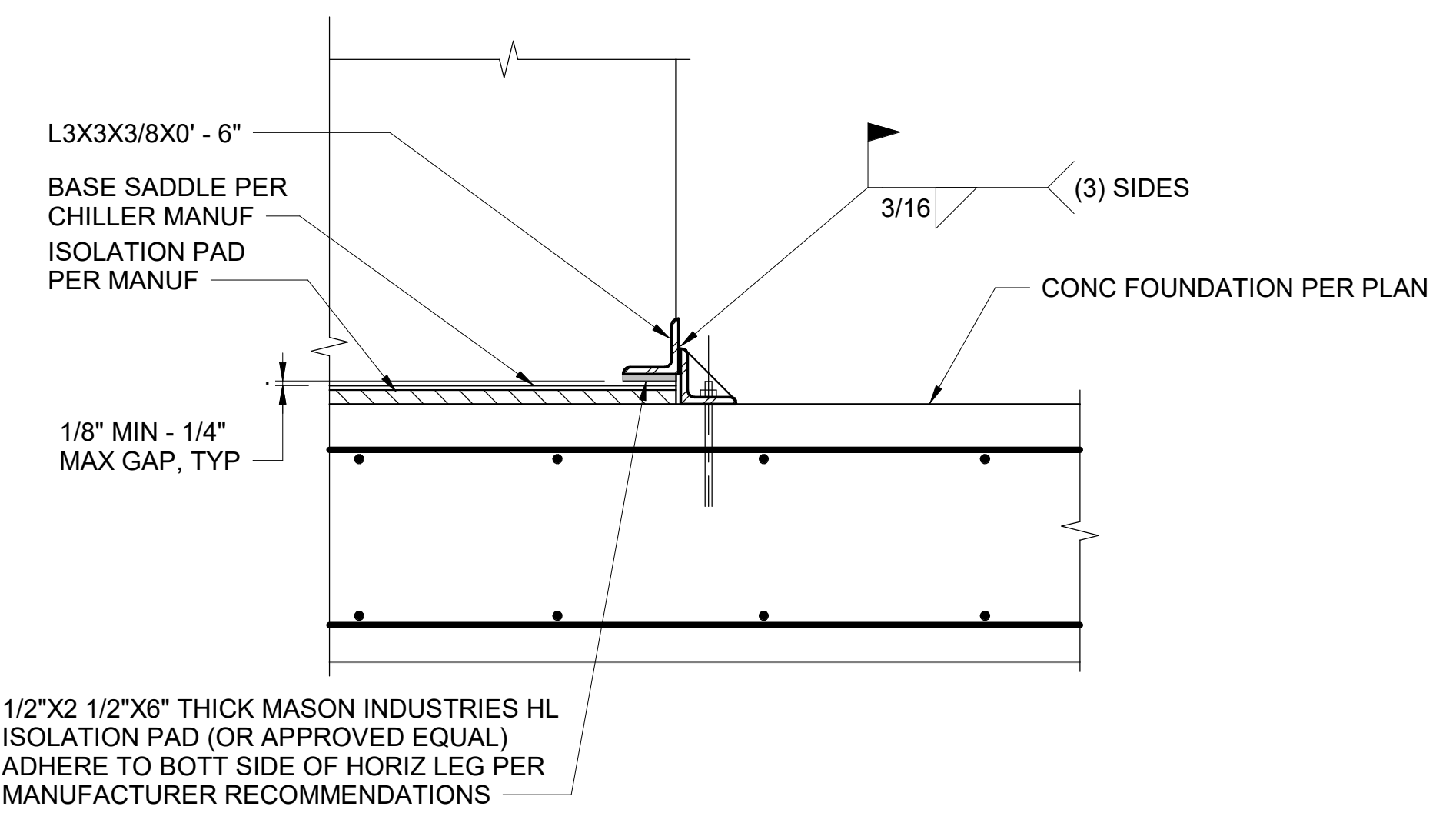

**E3 ANCHORAGE SECTION**  
S-514 SCALE: 1 1/2" = 1'-0"

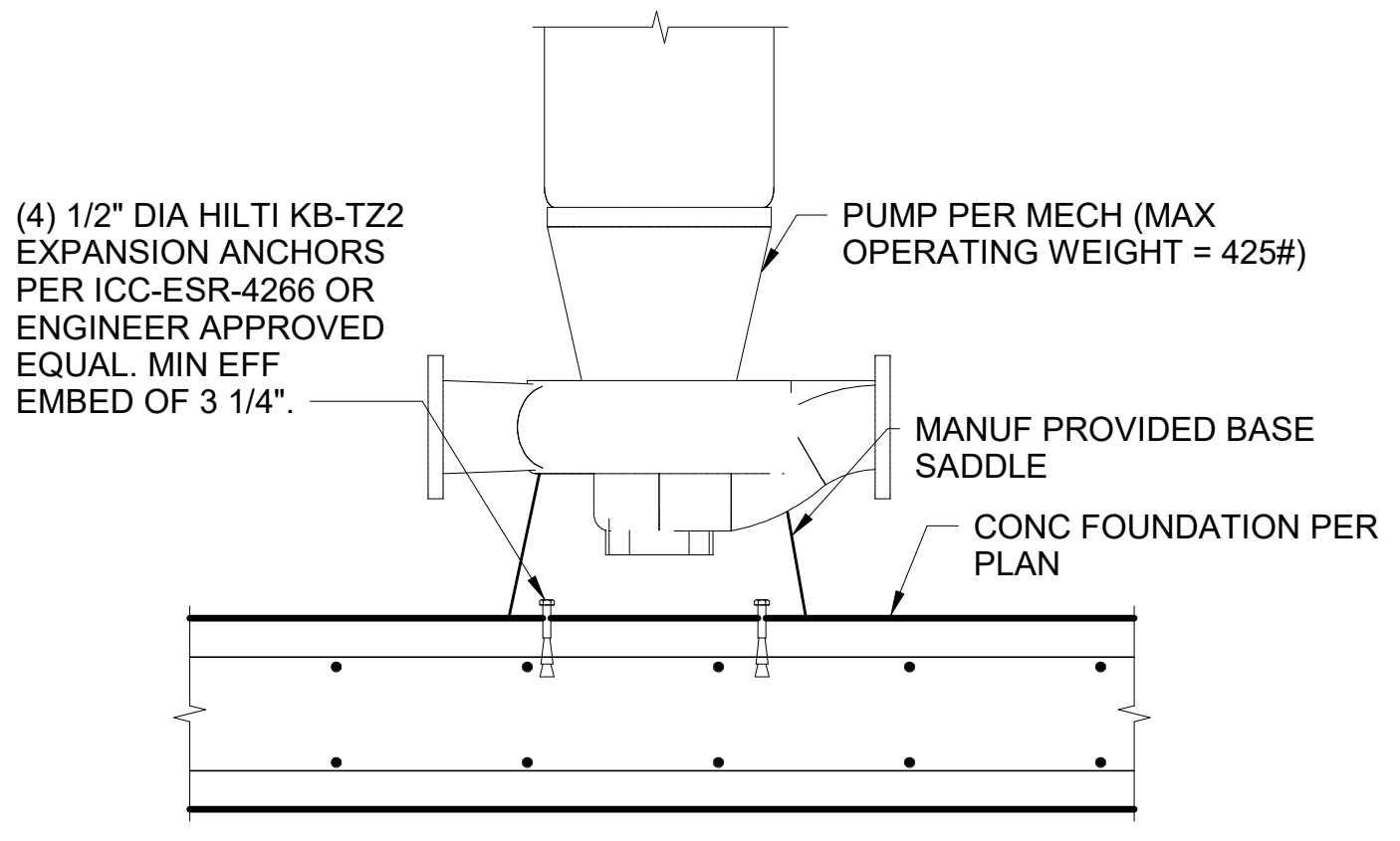

**E6 TYP VERTICAL PUMP ANCHORAGE**  
S-514 SCALE: 1" = 1'-0"

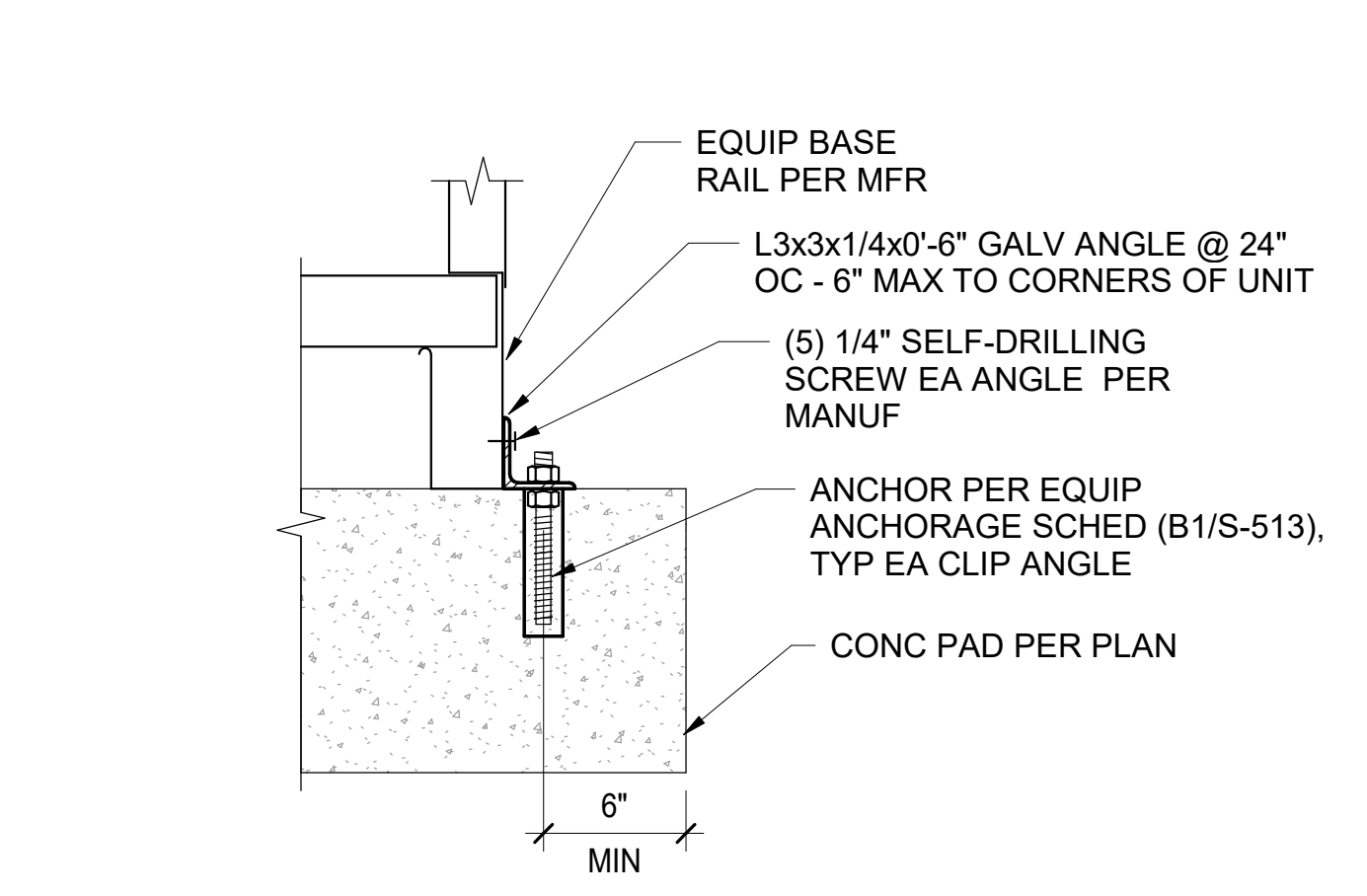

**F1 TYP ACU01-A1 ANCHORAGE**  
S-514 SCALE: 1 1/2" = 1'-0"

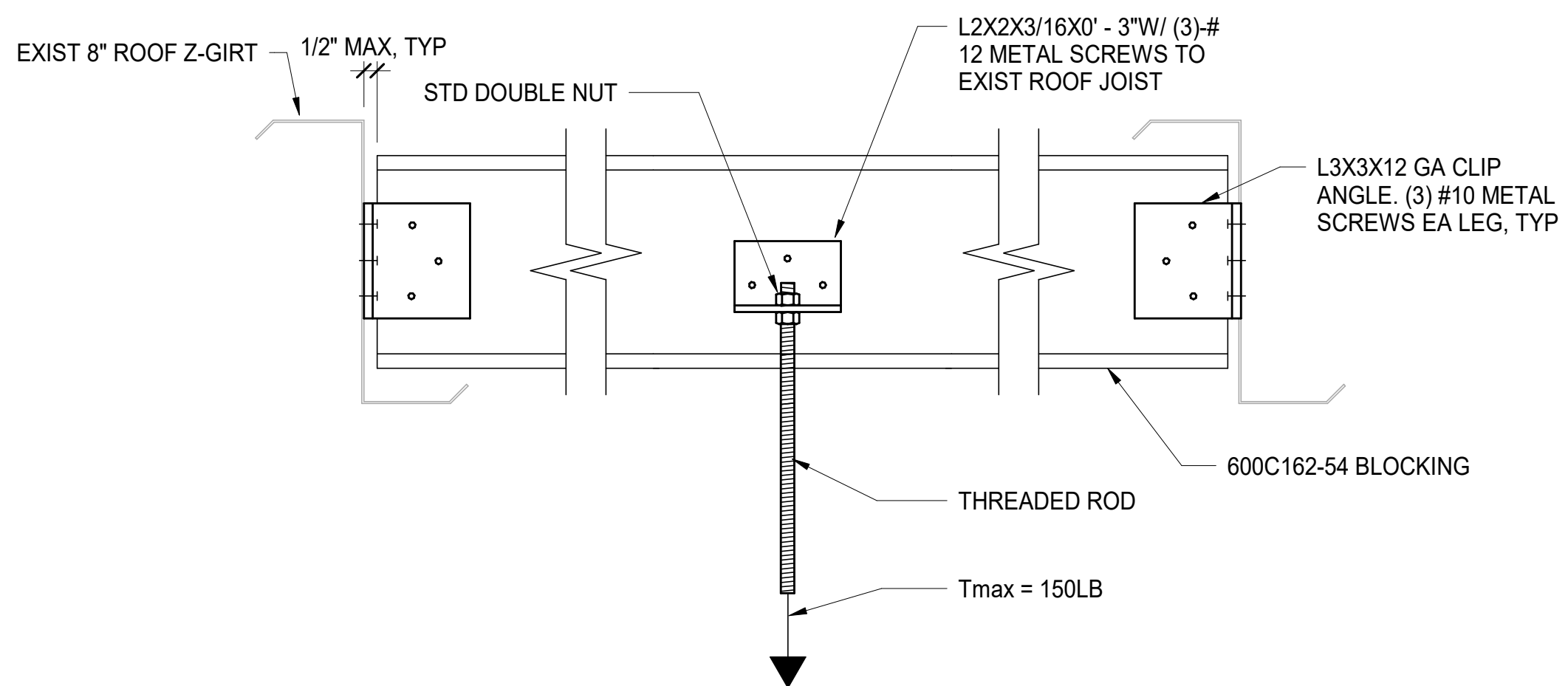

**F3 TYPICAL ROOF JOIST HANGER ATTACHMENT ROD DETAIL**  
S-514 SCALE: 3" = 1'-0"

Sheet Title	EQUIPMENT SUPPORT DETAILS
Dwg. No.	PLS2021-0432-0015D
Sht. No.	S-514